

WATER RULES, REGULATIONS, AND CONSTRUCTION STANDARDS

TOWN OF HALFMOON CONSOLIDATED WATER DISTRICT & WATER DISTRICT NO. 1 Saratoga County, New York



**Town of Halfmoon
111 Route 236
Halfmoon, New York 12065
(518) 371-7410**

Adopted by Town Board – May 20, 1997

**Amended: July 1, 1997
September 19, 2000
April 16, 2002
May 18, 2004
April 18, 2006
November 20, 2007**

TABLE OF CONTENTS

I.	INTRODUCTION.....	1
A.	INTENT	1
B.	SCOPE	1
C.	DEFINITIONS.....	1
II.	APPLICATION FOR WATER SERVICE	2
A.	LARGE TAPS (2-INCH AND GREATER).....	2
B.	SMALL TAPS (HOUSHOLD AND SMALLER THAN 2-INCH)	3
C.	WATER COMMITMENT APPLICATION PROCESS	4
III.	SERVICES	8
A.	HOUSEHOLD (ONE AND TWO FAMILY RESIDENTIAL)	8
B.	COMMERCIAL AND INDUSTRIAL.....	8
C.	LIMITS OF SINGLE SERVICE USAGE	8
D.	ACQUISITION OF PERMITS.....	9
E.	CONSTRUCTION METHODS	10
F.	MAINTENANCE RESPONSIBILITY	10
G.	LEAKAGE AND DAMAGE.....	12
IV.	LIMITING CONDITIONS AND RESTRICTIONS	13
A.	SERVICE TAPS	13
B.	RESPONSIBILITY.....	13
C.	BACKFLOW PREVENTION	13
D.	WATER USE RESTRICTIONS.....	14
E.	RELEASE FROM RESPONSIBILITY	14
F.	DISCONTINUED SERVICES	15
G.	EMERGENCY WORK.....	16
H.	OBLIGATION OF USER FOR ACCESS.....	16
I.	USE OF HYDRANTS, VALVES, AND OTHER DISTRICT FACILITIES	16
J.	LAWN SPRINKLERS.....	16
V.	CONSTRUCTION STANDARDS.....	17
A.	GENERAL	17
B.	DUCTILE IRON PIPE AND FITTINGS	17
C.	GATE VALVES AND VALVE BOXES	18
D.	FIRE HYDRANTS	19
E.	WATERLINE BLOWOFFS	21
F.	WATER SERVICES	22
G.	COPPER WATER SERVICE PIPE & FITTINGS.....	22
H.	CORPORATION STOP AND VALVE	23
I.	BRANCH CONNECTIONS.....	23
J.	CURB STOPS AND BOXES	24
K.	WATER METERS.....	24

L.	INSTALLATION OF WATER SYSTEM	24
M.	THRUST BLOCKING AND RESTRAINT	26
N.	CONNECTION TO EXISTING SYSTEMS	27
O.	TEMPORARY PLUGGING	27
P.	CLEANING LINES	27
Q.	HYDROSTATIC TESTING.....	27
R.	DISINFECTION.....	28
S.	TIME OF CONSTRUCTION.....	28
T.	RECORD MAPS AND CERTIFICATION.....	28
U.	WATER DISTRICT CONTROL	29
VI.	ADMINISTRATION	30
A.	GENERAL	30
B.	ENFORCEMENT OFFICER.....	30
C.	ENFORCEMENT	30
VII.	FEES & SCHEDULE	33
A.	WATER METER AND INSTALLATION FEE	33
B.	SERVICE WORK.....	33
C.	WATER SYSTEM ASSESSMENT SCHEDULE	33
D.	DISTRICT EXTENSION FEE	37
E.	APPLICATION REVIEW	37
VIII.	DOMESTIC WATER RATE SCHEDULE.....	38
IX.	MANUFACTURING WATER RATE SCHEDULE.....	39

Appendix A – Standard Details

I. INTRODUCTION

A. INTENT

The ensuing rules, regulations, and construction standards are adopted by the Town Board of the Town of Halfmoon (herein referred to as “Town”), Saratoga County, New York and shall be considered to be a part of the contract with any individual, partnership, corporation or other entity that is or shall be supplied with potable water within the bounds of the Town of Halfmoon Consolidated Water District and Water District No. 1.

It is further the intent of this document to promote uniformity and standardization of materials and procedures used in the construction and installation of all public water supply facilities built within the bounds of the Town of Halfmoon Consolidated Water District and Water District No. 1.

B. SCOPE

The construction standards presented herein include standards for appurtenances used in the installation of water service lines as well as major distribution system facilities. Source, treatment and storage facilities are not covered herein.

C. DEFINITIONS

As used in these specifications, the following words are defined:

Director of Water - shall mean the Town of Halfmoon Director of Water, Town of Halfmoon, Saratoga County, New York. Whenever the words ‘ordered’, ‘directed’, ‘required’, ‘approved’, or ‘accepted’ or variations thereof are used, they shall refer to action by the Director of Water of the Town of Halfmoon Water Department, or his designated representative(s), unless otherwise specified.

Owner - shall mean the Owner or the party who is employed by the Owner to design and supervise construction of the water distribution system. Also referred to as “customer”.

Contractor - shall mean the party who is employed by the Owner to actually construct the water distribution system.

Water main - shall generally mean pipe six inches (6”) diameter or larger supplying water as part of a system to one or more buildings.

Water services - shall generally mean pipe smaller than six inches (6”) in diameter supplying water to one or more buildings.

II. APPLICATION FOR WATER SERVICE

A. LARGE TAPS (2-INCH AND GREATER)

1. Application Procedure

Pipes of two inch diameter or larger tapped into a water main shall be deemed to be a large tap. No large tap shall be made unless application has been duly made by the applicant to the Town.

2. Approved Plans

Permission to make a large tap shall not be granted prior to the presentation of engineering drawings depicting the exact location and method to be used in making the tap. Said plans and specifications shall be approved by the Town for the tap before it is made.

3. Payment

The appropriate payment shall be paid in full prior to the making of the tap. A schedule of current fees can be found in Section VII of these regulations.

4. Notification

At least ten (10) days prior to the making of a tap, the Town shall be notified in writing as to the intent of the person desiring the tap. It shall be that person's responsibility to arrange a meeting to discuss the tap with the Director of Water of the Town of Halfmoon.

5. Acceptable Materials and Methods

All materials to be used including pipe, valves, corporation stops, curb stops, flexible couplings, tees, etc., shall comply fully with the material specifications as outlined in Section V of this document.

The work shall be performed in a manner acceptable to the Town and shall be inspected and reviewed by the same. Backfilling of work shall not take place until proper inspections have been made and approval of the work has been given by the Director of Water or his authorized representative.

B. SMALL TAPS (HOUSEHOLD AND SMALLER THAN 2-INCH)

1. Application Procedure

Prior to the installation of a household tap or a tap smaller than two inches, an application for the same shall be made on the form provided by the Town. Execution of this document and payment of the appropriate tapping fees shall take place prior to the installation.

2. Payment

The appropriate payment shall be paid in full prior to the making of the tap. A schedule of current fees can be found in Section VII of these regulations.

3. Allowable Minimum Size

The minimum allowable tap for potable water service shall be 1-inch. Larger taps will be required by the Town when lengthy runs are needed or when the service point is substantially higher in elevation than the water main.

4. Acceptable Materials and Methods

All materials to be used including pipe, valves, corporation stops, curb stops, flexible couplings, tees, etc., shall comply fully with the material specifications as outlined in Section V of this document.

The work shall be performed in a manner acceptable to the Town and shall be inspected and reviewed by the same. Backfilling of work shall not take place until proper inspections have been made and approval of the work has been given by the Director of Water or his authorized representative.

5. Responsibility for Installation

a. Obligation of the Owner

The Owner is obligated to install the necessary and required service piping and related materials at his own expense with the exception of the tap and the meter installation. The Owner is also obligated to assure the Town that no water service shall extend from one dwelling unit to another dwelling unit and that no unmetered water shall be expended.

At the time of the installation or before, the Owner shall disconnect any pipe carrying water from any other source (e.g. a water well) or pipe or piping any other kind as stipulated in State Sanitary Code Part 5, Subpart 5-1.31(c). The connection of any pipe or conduit servicing the supply of water of Halfmoon Consolidated Water District and Water District No. 1 is strictly prohibited.

During the construction of the water service line, the Owner shall at all times be responsible for the trench in which the pipe is placed and any alleged damages resulting from this installation. All restoration work in public rights-of-way shall be completed by the Owner to the satisfaction of the Town.

b. Obligation of the Town

The Town may, at its discretion, make available for sale certain materials to be used in the construction of the service line. In the event these materials are not available when desired, the Owner will be directed to a location at which the items may be purchased.

All residential service taps will be made by the Town, unless other arrangements have been approved by the Director of Water. The Director of Water shall approve all locations of water service lines.

Meters, related hardware, and remote registers will be installed and sealed by the Town and the Owner will be billed for this service as outlined in Section VII. This amount may be required to be paid at the time of payment for the tap.

c. Approval of the Work

The installation of all water service lines shall be inspected and approved in writing by the Director of Water or his authorized representative before being covered.

C. WATER COMMITMENT APPLICATION PROCESS

The following three pages outline the application process for water commitments.

WATER COMMITMENT APPLICATION PROCESS

- I. Applicant requests the Town to provide water to the property. The Water Department will make a determination if the needed water capacity is available. A water commitment will not be made at this time.
- II. The location of the property is reviewed in relation to the district boundary. Extension of the Town's Consolidated Water District is required for those properties located outside the boundary. The Town will not agree to an extension of the Consolidated Water District unless and until a Water District Extension Agreement has been executed by the Applicant and all mandated fees have been paid to the Town.
- III. Preliminary Planning Board Review Process
 - A. The Applicant proceeds to preliminary plan approval at own risk. A letter of risk acknowledgement is executed by the Applicant.
 - B. Preliminary plans are submitted to the Planning Board for review.
 - C. In District Users
 1. The Applicant submits an Engineering Report with the preliminary plans.
 - D. Out of District Users
 1. The Applicant submits the following:
 - a) NYSDEC Water Supply Permit Application, including Engineering Report and completion of State Environmental Quality Review (SEQR) with a Negative Declaration.
 - b) Map, Plan, and Report for extension of the Consolidated Water District.
 - E. All submitted items are reviewed by the Town Water Department and the Town Engineer as part of the preliminary review process.
- IV. Preliminary Planning Board Approval
 - A. After the Planning Board grants preliminary approval to the subdivision, the Town Attorney will begin preparation of the draft Water District Extension Agreement. The agreement will include information on the required Water District Extension Fees as follows:
 1. TOTAL AMOUNT of fees required in the Agreement will be paid in full, prior to signing of Extension Agreement.

2. The Extension Agreement shall detail if the project is proceeding with the extension in phases. If the Extension Agreement details phase extensions, no plans shall be stamped that details entire subdivision approval as no approval can be granted without a potable water source. Phased maps will be stamped in accordance with the Extension Agreement.
 3. At the time of extension of the Water District representing 75% of the entire project, the balance of the Water District Extension Fee must be submitted, in full, to the Town.
 4. Any other information deemed appropriate by the Town Attorney will be provided.
- B. For out of district users, the Town Board will pass a resolution authorizing the Town Supervisor to execute the Consolidated Water District Extension Agreement once the mandatory fees are paid in full. A Water District Extension Agreement is not required for in district users.
- C. Applicant submits packages including reports, applications, Water District Extension Agreement, SEQR Negative Declaration and preliminary plans to NYSDEC/NYSDOH for review, approval and stamping of plans. For in district users, a submission to NYSDEC is not required.
- D. The Applicant has eighteen (18) months to complete the preliminary approval process for the water commitment. This timeframe does not supersede any other pertinent statutes relative to planning board approval. If the process is not completed within this time, the water commitment shall be deemed to have expired. The Applicant may request, in writing, to the Town Board for an extension of the eighteen (18) month period so long as the request is made more than thirty (30) days prior to the expiration of the commitment. If the Applicant does not request an extension, or if the request is denied, the Applicant will be required to re-file their Water Commitment Application to obtain municipal water as the previous commitment will be deemed null and void. Upon the failure of the Applicant to request, in writing, an extension more than thirty (30) days prior to the expiration of the commitment or if the Town Board does not grant the extension, any and all fees collected in association with the application process shall be retained by the Town of Halfmoon.

V. Final Planning Board Approval

- A. Applicant will return to the Town Planning Board with plans once agency approvals are in place. The Town must be advised in writing of any modifications made to plans that were granted preliminary approval as a result of Agency comments. Once approved by the Planning Board, Final Plans, if acceptable, will be stamped by the Water Department prior to final stamping by the Planning Board.

- B. The Applicant has eighteen (18) months following preliminary Planning Board approval to obtain all agency approvals and stamps necessary for final planning board approval. If the agency approvals are not obtained within this time, the water commitment previously provided to the Applicant will be null and void.
- C. The Applicant must proceed to construction after final approval, within a term that is determined by the Town Board; minimum of twenty-four (24) months. If construction does not commence during this time, the water commitment will be null and void.

VI. Withdrawal of Water Commitment

- A. In addition to the items listed above, the water commitment will be withdrawn by the Town under the following conditions:
 - 1. Construction is not substantially complete within the time period set forth by the Town Board.
 - 2. An interruption or substantial discontinuation of the work occurs for a period of time determined by the Town Board.
- B. If Applicant does not complete the project within the time set forth by the Town Board, Applicant can apply, in writing, for an extension of the time for substantial completion to the Town Board thirty (30) days prior to the expiration of the time period for substantial completion. The Town Board shall review the request and grant or deny the request at the Boards discretion.

III. SERVICES

A. HOUSEHOLD (ONE AND TWO FAMILY RESIDENTIAL)

1. Materials
 - a. Service Piping

Household service lines shall be of Type K seamless copper tubing as outlined in Section V.H of this document. The minimum acceptable service size shall be one inch. Larger sizes may be required as outlined in Section II.B.3 of this document.

B. COMMERCIAL AND INDUSTRIAL

1. Definition

For the application of these rules, regulations, and construction standards, any water service that serves a dwelling unit or building that contains four or more separate dwelling units shall be considered a commercial water service. All sales, manufacturing, recreation, and service facilities shall be classified as commercial/industrial.

2. Application

The stipulations set forth in the previous section regarding household meters shall apply to this section as well. Tap sizes may vary and the proposed tap size shall be approved by the Town in writing. Engineering plans and specifications may be required.

3. Backflow Preventor

A backflow preventor is required in all applications and shall be in accordance with the approved list published by the New York State Department of Health.

C. LIMITS OF SINGLE SERVICE USAGE

1. Residential

A service line shall be designed to serve one dwelling unit property. The extension of water service line from one dwelling to another shall not be permitted. Special approval may be granted to service more than one dwelling unit. This may be done if such special approval is granted in writing by the Director of Water.

2. Commercial and Industrial

Service lines which serve commercial or industrial lines shall be so designed that no unmetered water may be drawn. In certain cases, protection against back-siphonage may be required as stipulated in Part 5 of the State Sanitary Code, Subpart 5-1.31.

Generally, fire fighting systems and sprinklers will be fed from separately installed water mains sized larger than service lines. All fire fighting water systems shall be approved by the Director of Water in writing prior to being installed.

3. Special Cases

Service lines serving apartment houses, town houses, condominiums and similar facilities shall be reviewed on an individual basis. The number and size of service lines providing water to such installations shall be approved by the Town prior to installation.

D. ACQUISITION OF PERMITS

1. Town Right-of-Way

All excavation and other construction work to be performed within the Town's right-of-way shall be done only with the approval of the Town Highway Superintendent or his authorized representative. All restoration work shall be performed to the satisfaction of the Town Highway Superintendent or his authorized representative upon filing required certificates of insurance naming the Town of Halfmoon as an additional insured in such amounts as the Town requires, together with copies of any construction contracts, required surety bonds, performance, payment bonds, letter of credits, etc., as determined by the Town Highway Superintendent and Town Engineer.

2. County Right-of-Way

All work within a Saratoga County right-of-way shall be performed only if permission is granted to do so by the Saratoga County Department of Public Works. A permit to perform any such construction must be obtained from that department prior to the commencement of any work. Restoration shall be performed to the satisfaction of that department.

3. State Right-of-Way

All work within a Saratoga County right-of-way shall be performed only if permission is granted to do so by the New York State Department of Transportation. All necessary permits must be obtained and other requirements must be met prior to the commencement of work. The performance of the work and all restoration must be to the satisfaction of that department.

4. Other Right-or-Ways

No work in privately owned right-of-way shall be commenced until permission is obtained for the performance of the work, in writing, from the property owner. The property owner may, at his option, request evidence of proper insurance coverage from the party performing the work. The manner in which the work is performed and the areas restored shall be satisfactory to the Owner and Town.

E. CONSTRUCTION METHODS

1. Public Safety

Proper consideration shall be given to the public safety during construction of water service lines. In order to assure that pedestrians and vehicular traffic is protected, the Contractor shall supply the Town with a certificate of insurance that is acceptable to the Town and that clearly shows the nature and limits of his insurance coverage. The Town shall be named as an additional insured on the insurance policy. The Contractor shall provide necessary flagmen or other precautionary measures necessary to insure public safety. No excavations shall be left open after the conclusion of the work day and all irregularities in the road, walkway or elsewhere shall be clearly and visibly marked by means of barricades, burning pots or other acceptable means of providing warning that a danger exists.

2. Minimum Cover

Minimum cover over service lines, to provide protection against frost, shall be at least five feet at all points from the main to the entry point (house or building foundation). Care shall be exercised in areas of new construction to assure that grading performed after the service installation does not cause final grading to reduce the cover to less than five feet.

3. Separation From Other Utilities

Water service lines shall be separated horizontally from sewer or drain lines a minimum of ten feet; vertical separation above and below shall be at least eighteen inches in accordance with the Recommended Standards for Water Works. Service lines shall not be placed in trenches with other utilities including sewer, drainage, gas, electrical conduit or other.

4. Inspection of Completed Work

All work performed by private Contractors or Owners shall be inspected and approved by the Town in writing. No portion of the installation shall be backfilled or covered prior to being approved.

F. MAINTENANCE RESPONSIBILITY

1. Town

It shall be the responsibility of the Town to maintain, repair as needed, and keep in good working order, all service lines from the main (corporation stop) to but not including the curb stop. The repair of leaks or other damage occurring to service lines within this area shall be performed by the Town at its own expense, unless the repairs are due to activities of the homeowner, their agents, servants, and/or employees.

The Town will be responsible for repairing paved driveway, sidewalks, and lawns for a maximum of one (1) year after the initial installation/repair takes place.

2. Owner

It shall be the responsibility of the Owner to maintain in proper working order the service from and including the curb box to the entry point beyond the meter. No pipe beyond the meter shall be permitted to be buried. A broken curb box or lid should be brought to the immediate attention of the Director of Water. The expense of repair work performed on any curb box shall be paid by the Customer.

3. Water Meters and Interior Valves

a. Water Meters

Water meters shall be purchased and owned by the Customer. However all repairs shall be performed by the Town. The Customer is cautioned that tampering with any meter or breaking the seal of any meter is a violation of law and is punishable by law. Irregularities, leaks, or other problems with meters or remote registers must be brought to the immediate attention of the Director of Water. Replacement of faulty meters will be performed by the Town at the owners cost. Similarly, the repair of meters that leak will be performed by the Town at no charge except as hereinafter provided. The cost of repair of any meter with any malfunction attributable to negligence or carelessness on the part of a Customer such as a frozen or abused meter, although repaired by the Town, shall be paid by the Customer in accordance with a fee schedule established by the Town.

b. Interior Valves

Valves located inside the dwelling shall be the responsibility of the Owner to maintain and repair as needed. Should repair work be necessary the Director of Water shall be notified and the system shut-off will be performed by the Town as outlined in Section III.F.4 of these regulations.

4. Temporary Water Service Shut-off

The Customer at any time may request that water service to their residence be shut off at the curb box for the purpose of doing repairs or in an emergency. In situations other than emergencies, ample prior notice shall be given to the Director of Water to perform this function. The reinstatement of service shall be accomplished in a similar manner. The operation of the curb stop shall be performed only by Town personnel. The fee charged for this service will be in accordance with Section VII of these regulations.

5. Permanent Water Service Shut-off

In certain cases, the Owner of a piece of property may desire to discontinue water service to a certain location permanently, such as in the case where a building

has burned or been demolished. Service lines for such situations must be shut off at both the curb stop and the main. Water service shut at the main will be accomplished by the Town and will essentially be the equivalent of the elimination of that service. Reinstatement of the service line, should it ever be desired, will involve the complete procedure for a new service including application and payment of the tapping fee.

G. LEAKAGE AND DAMAGE

1. Responsibility

Damage caused by the rupture or leaking of a water main or service line to the curb box shall be the responsibility of the Town to repair and replace-in-kind, unless the damage is caused by activities of the homeowner, their agents, servants, and/or employees.

When damage occurs to private property it shall be the responsibility of the Owner to notify his insurance carrier of the damage and for that carrier to assume the burden of payment for damages, whenever possible.

IV. LIMITING CONDITIONS AND RESTRICTIONS

A. SERVICE TAPS

No person other than an employee of the Town shall at any time perform a tap on a Town water pipe or connect or attach any pipe, conduit or main to any Town pipe unless approval has been granted in writing to do so by the Town nor shall any attachment or connection be made that permits the use of unfettered water to be used. Tapping into water mains, open cutting, or boring of any water services when the air temperature is below 32° F will generally not be allowed. The Owner must be granted special permission to tap water mains when the air temperature is below 32° F by the Town of Halfmoon Water Department. All service connections shall be pressure tested by the Contractor.

B. RESPONSIBILITY

Damage done to any portion of property as a result of damage to the service, mains, hydrants, curb boxes, or other fixtures or structures shall be the responsibility of the person, firm, or corporation for whom the work is being performed. Repair or replacement of damage shall be performed to the satisfaction of the Town and the Director of Water at his discretion. The Director of Water shall prepare a statement of the cost of repair, in writing, and the Town shall be paid the amount of such cost within thirty (30) days of notification of said amount by the Town.

C. BACKFLOW PREVENTION

1. Existing Water Wells

As outlined in Section II.B.4.a of these regulations, the State Health Department requires a physical disconnection from existing individual water wells to the piping connecting to a public water supply system. The purpose of this requirement is the elimination of potential back siphonage and possible contamination of the public water supply. Under no circumstances, including valving, check valves, vacuum breakers and other devices, shall a direct connection be made or permitted between a privately owned water well and the public water supply. Inspections shall be made by Town personnel to assure that this rule has been carried out. Failure to meet this requirement constitutes a violation that can be prosecuted as a violation or a crime. Violators of this rule shall be immediately shut-off at the curb stop and service shall not be returned until compliance with this section has been met.

2. Other Potential Contaminants

The Town shall require protection against the possibility of back-siphonage in all areas deemed appropriate consistent with the potential degree of contamination possible. This shall include, but not be limited to, cross or interconnections with sewers, areas where hazardous chemicals are used, manufacturing plants, and any other contaminant considered to be a potential threat to the potability of the public water supply.

The degree of protection required shall be contingent upon the severity of the situation and may require an air gap, reduced pressure zone device, double check valve assembly or other measure and shall be consistent with the requirements of the New York State Health Department Cross Control Connection Manual.

3. Authority of the Town

The Town retains the authority to discontinue immediately water service to any entity, residence, or facility deemed to have potential to cause contamination of any kind to the potable water supply.

D. WATER USE RESTRICTIONS

The use of water at any premises or facility shall be consistent with the generally understood intent for use. Water used for the prevention of freezing in piping shall generally be discouraged but may be permitted provided that the Director of Water agrees to the concept and all water run for this purpose is metered.

Water used to flush sewers or soil pipes shall be done only under direct supervision of water district personnel and shall be performed in a manner acceptable to the Director of Water and so as not to provide a cross or interconnection of any kind.

Unmetered water shall not be used, with the exception of fire fighting usage, without the knowledge and permission of the Director of Water. Arrangements shall be made to accurately ascertain the amount used. Payment for same, if required, shall be made based upon such determination.

The Town reserves the right to limit the amount of water furnished to any Customer should circumstances warrant such action without prior agreement or may discontinue or interrupt water used for manufacturing, cooling, lawn sprinkling, should it become necessary after rendering reasonable notice, whenever possible, to the Customer.

Interruptions in service caused by emergencies will occur from time-to-time. Prior notification of such interruptions will be attempted but shall not be the responsibility of the Town and the right is reserved by the Town to repair mains as needed.

E. RELEASE FROM RESPONSIBILITY

1. Fluctuation in Pressure

The Town shall not be held responsible for any damages due to fluctuation in or lack of pressure within the distribution system.

2. Disruption in Water Service

Notification to Customers of water outages due to routine construction or other scheduled or planned work will be made by the Town whenever possible. Emergencies, as outlined in Section IV.D, since repair must be immediate, do not permit notification and the Town assumes no responsibility to provide that service. Emergencies include outages due to a break in a water main, pumping equipment failure, system contamination, terrorist activities, acts of nature, and any other acts outside of the control of the Town.

F. DISCONTINUED SERVICES

1. Temporary Shut-off

A temporary shut-off shall be defined as water service that has been shut off at the curb stop. (See Section III.F.4)

a. Seasonal

Should the Customer desire to have water service temporarily discontinued, advance notification shall be made to the Town in writing. Service will be shut off at the curb until further notice. The minimum billing charge will be in effect for the duration of the shut-off.

b. Undetermined Time Period

The procedure established above shall be effective when the temporary time period is not determined. The minimum billing charge shall be in effect for the shut-off period.

2. Permanent Shut-off

a. Responsibility

Once a determination has been made to permanently discontinue water service to a location, the Owner will excavate the service at the main and Town personnel will shut off the corporation stops. The service will then be considered eliminated and no further water usage charges made. The Owner will still be required to pay capital debt retirement, special assessments, etc.

b. Return to Service

In the event it should be desired to re-activate a permanently shut-off service, it shall be mandatory for the Owner to re-apply to the Town and pay the tapping fee. The excavation to turn the service on shall be performed and paid for by the Owner. The Town will inspect the corporation stop for soundness and return it to service if it is found to be sound.

Replacement of any faulty corporation stop shall be the responsibility of the Town. Retapping the main at a new location may be required.

G. EMERGENCY WORK

Emergency work performed within a residence or other building shall be completed by the Owner. Emergency work performed by the Town on an Owner's property (not within the home) shall be done only at the discretion of the Director of Water or his deputies. Work performed and materials used shall be billed to the Owner in accordance with the fee schedule in Section VII.

H. OBLIGATION OF USER FOR ACCESS

It shall be the obligation of the user to allow ready access for Town personnel to make routine inspections, perform functions related to the water service, read meters, etc., to all premises being supplied with water.

I. USE OF HYDRANTS, VALVES, AND OTHER DISTRICT FACILITIES

No hydrant, valve, or other property of the Town shall be used without permission of the Director of Water. The use and manner of use shall be described to the Director of Water in writing. The use of the facility shall be limited to that usage approved.

J. LAWN SPRINKLERS

1. Rain sensors are required on all installations. These sensors must override the programmable operation of automatic lawn sprinkler devices.

2. A double check valve backflow preventor is required for all lawn sprinkler systems to protect the Town water system. Backflow preventors shall be in accordance with the approved list published by the New York State Department of Health.

3. Outdoor shutoff valves which allow the Town Water Department personnel to manually shutoff the automatic sprinklers in cases of emergency or watering violations must be in place and identified.

V. CONSTRUCTION STANDARDS

A. GENERAL

1. The following specifications apply to all water mains and services installed on public or private properties that are connected directly or indirectly to the Town of Halfmoon Water System. All plans and specifications for such water mains shall be reviewed and approved in writing by the Director of Water or Town Engineer prior to construction.

2. Standard Detail Sheets 1 through 6 of the Halfmoon Water Department supplement these specifications and shall be considered an integral part hereof. The Standard Detail Sheets are found at the end of this document.

3. In the event that the specified item no longer exists, the Director of Water will specify a substitute product and manufacturer.

B. DUCTILE IRON PIPE AND FITTINGS

1. All pipe for water mains 6 inches through 16 inches in diameter and for water services larger than 2 inches in diameter shall be ductile iron pipe. All ductile iron pipe 4 inches in diameter and larger shall be furnished in 18 or 20 feet nominal laying lengths. High density polyethylene (HDPE) or polyvinylchloride (PVC) water main is allowed after master meter pits in areas that the Town of Halfmoon will not own or maintain.

2. All buried pressurized ductile iron pipe shall be centrifugally cast Class 52 pipe in accordance with the latest version of ANSI/AWWA C151/A21.51.

3. All buried pressurized ductile iron pipe fittings shall be ductile iron in accordance with the latest version of ANSI/AWWA C110/21.10 or ductile iron compact fittings in accordance with the latest version of ANSI/AWWA C153/A21.53

4. All pipe shall have push-on joints in accordance with the latest version of ANSI/AWWA C111/A21.11. The pipe manufacturer shall furnish the required rubber joint gaskets and joint lubricant together with two (2) Silicon Bronze Wedges with each length of pipe. The two (2) wedges shall be installed in each pipe joint several joint. Care shall be taken to insure that these wedges do not drop out or become displaced due to movement of the pipe during laying and backfilling.

5. All ductile iron pipe for hydrant connections, minimum size 6-inches in diameter, shall conform to the same specifications as given previously for main line ductile iron pipe; except that hydrant connection pipe shall have mechanical joints in accordance with the latest version of ANSI/AWWA C111/A21.11.

6. The pipe manufacturer shall furnish the required joint accessories consisting of ductile iron glands, high-strength low-alloy steel tee bolts and nuts, plain rubber gaskets, and required joint lubricant.

7. All buried ductile iron pipe and ductile iron fittings shall be cement mortar lined and point seal coated in accordance with the latest version of ANSI/AWWA C104/A21.4. The thickness of the lining shall be twice the standard and shall be not less than 1/8 inch thick for all pipe 3 inches through 16 inches in diameter.

8. All buried ductile iron pipe and fittings shall be furnished with a 1-mil thick standard petroleum asphaltic coating in accordance with the latest version of ANSI/AWWA C151/A21.51.

9. All buried ductile iron pipe and fittings shall be wrapped with polyethylene encasement in accordance with the latest version of ANSI/AWWA C105/A21.5

C. GATE VALVES AND VALVE BOXES

1. All gate valves, 3-inch through 12-inch, shall be in accordance with the latest version of AWWA C509 and shall be UL listed and FM approved. Gate valve spacing shall be in accordance with the Recommended Standards for Water Works, latest edition.

2. Valves shall have working pressure of 250 psi. Valves shall be tested and certified to ANSI/NSF 61. Each valve seat shall be factory tested at 250 psi and each valve shell shall be factory tested at 500 psi.

3. All gate valves shall have a non-rising stem. Stem shall be bronze rolled bar stock with forged thrust collar.

4. Non-rising stem gate valves shall have a 2-inch square operating nut. Operating nut shall be attached to the stem with a bolt that is recessed into the operating nut to prevent interference with the operation of the valve wrench. The valve shall have an arrow cast on the operating nut showing the opening direction. Valves shall open left (counter clockwise) unless specified otherwise.

5. All gate valves shall have an o-ring sealed stuffing box. Two o-rings shall be located above and one o-ring located below the stem thrust collar. Stuffing box shall have Type 304 stainless steel nuts and bolts.

6. The body and bonnet of all gate valves shall have a wall thickness conforming to AWWA C509. Valves with a reduced wall thickness are not acceptable. Bonnet shall have Type 304 stainless steel nuts and bolts.

7. All gate valves shall have a disc and guide lugs fully encapsulated in rubber. Guide lugs shall be equipped with bearing caps to prevent abrasion and reduce torque.

8. The interior and exterior ferrous surfaces of all gate valves shall be coated with a fusion bonded thermosetting powder epoxy coating conforming to AWWA C550. Coating shall have a thickness of 10 mils.

9. Provide resilient wedge gate valve as manufactured by Mueller Co., Model A-2360.

10. All valve boxes shall be of cast-iron, slide-type, at least five and one-quarter inch (5-1/4") in diameter. Valve boxes shall be two (2) piece and shall be furnished to match the specific valve dimensions and trench depth as shown on the drawings.

11. All valve boxes shall be furnished with a cast-iron cover, drop style, with both the word "WATER" and an arrow indicating the direction of valve opening (open left) cast on the cover in raised characters. The arrow shall also be labeled with the word "OPEN".

12. Furnish one (1) steel socket key for each five (5) valves of the same size or less. The length shall be compatible with valve with the greatest depth of bury.

13. Gate valve and valve box installation shall conform to all requirements included herein. All hydrant leads shall incorporate a gate valve which in general, shall be located as far from the hydrant and as close to the main as possible. Gate valves at main line junctions shall be located 4 feet away measured center of the valve to the center of the junction or fitting, as shown on Figure 1. Gate valves on ductile iron water services shall generally be located on the street line or property line or where required by the Town of Halfmoon Water Department. All gate valve locations shall be reviewed and approved by the Director of Water prior to valve installation and preferably during the design of the system. Tops of the valve boxes shall be set flush with grade in paved areas and set 1 inch above grade in grassed areas.

D. FIRE HYDRANTS

1. All fire hydrants shall be in accordance with the latest version of AWWA C502. Hydrants shall also be UL listed and FM approved. All hydrants shall have working pressure of 250 psi and factory tested at 500 psi. Hydrant spacing shall be in accordance with the Recommended Standards for Water Works, latest edition.

2. All hydrants shall have a reversible, compression type main valve. Main valve seat shall be 5-1/4 inch diameter. Main valve shall open against pressure and close with pressure for positive seal. Hydrants shall be equipped with two (2) drain valves to drain barrel when hydrant is closed. Drain valves shall be bronze with threaded bronze drain ring.

3. All hydrants shall be three-way design with one (1) 5" storz pumper nozzle to follow fire department requirements and two (2) 2-1/2 inch hose connections with National Standard hose threads and outlet nozzle cap chains. All nozzles shall be threaded into the hydrant barrel and be replaceable in the field. The nozzle caps shall be the same size as the operating nut. The operating nut shall be a 1-1/2 inch pentagon one piece design. All hydrants shall open left (counterclockwise).

4. All hydrants shall be of break flange construction with a safety flange on the lower barrel located slightly above the ground. Hydrants shall also be equipped with a stainless steel, torque diverting coupling capable of releasing from the stem to prevent damage to the stem and main valve during contact with the hydrant.

5. All hydrants shall have an oil filled reservoir and lubricating system in the bonnet. Lubricating system shall automatically circulate lubricant to the stem threads and bearing surfaces each time the hydrant is opened.

6. All hydrants shall have a 6-inch Aqua Grip shoe (DIPS) as manufactured by Mueller Co.

7. Provide fire hydrant as manufactured by Mueller Co. Model Super Centurion 250 A-423.

8. All hydrant lead valves shall be 6-inch, resilient wedge gate valves with mechanical joint X Aqua Grip connections for DIPS pipe. Hydrant lead valves shall be Mueller Co. Model A-2361-78. All anchoring tees shall be mechanical joint, 6-inch x water main diameter. Anchoring pipe shall be 6-inch with Aqua Grip connections at gate valve and hydrant.

9. All hydrants shall be painted yellow after installation (including operating nut and nozzle caps). All hydrants shall be furnished completely shop primed with Tnemec Series 1. Paint coating for hydrants shall be as follows:

- a. Intermediate coat – Tnemec Series V27 Typoxy.
- b. Finish coat – Tnemec Series V73 Endura-Shield.

10. Hydrant markers shall be installed on all hydrants. Markers shall be made of steel with the following components and dimensions:

- a. Rod shall be 1/2" in diameter and 4' in length.
- b. Placard shall be 4" x 4" square and 1/8" thick.

11. Hydrant marker rod shall be welded to the placard. The bottom of the rod shall be bent into a 2-3/4" diameter circle so that it may later be affixed on the hydrant hose nozzle for support. All placards shall be shop primed with Tnemec Series 37 Chem-Prime Alkyd primer in white (37-77S) prior to being painted. Finished coat shall be Safety Orange Chromacolor (CA26). All rods shall be painted with Sable Chromacolor (BN08). All shop priming and painting of hydrant markers shall be done prior to installation, thereby allowing sufficient time for the coatings to dry.

12. Hydrant installation shall conform to the requirements on Figure 2 of the Standard Detail Sheets. The type of hydrant installation shall be installed truly vertical at the locations set by the Town Engineer and/or Town of Halfmoon Water Department and shall be carefully plumbed before the connection is made.

13. Hydrants shall be set on a solid precast concrete slab at least 12 inches square and 4 inches thick; the concrete slab to be supported by firm undisturbed material or well consolidated fill.

14. Crushed stone to a minimum thickness of 12 inches shall be placed around the drain up to a level at least 5 inches above the drain to provide for hydrant drainage in previous soil, such as sand or gravel. In impervious soil, such as clay, a drainage pit 2 feet in diameter and 3 feet deep shall be excavated below each hydrant and filled completely with crushed stone under and around the bottom of the hydrant up to a level at least 6 inches above the drain. In both cases, the top of crushed stone shall be completely covered with polyethylene or building paper to prevent the backfill from sifting down into the crushed stone drain.

15. When required by the Town Engineer and/or Town of Halfmoon Water Department because of evidence of high groundwater, the hydrant drain opening shall be plugged to prevent the entrance of groundwater. In this case, no crushed stone need be placed under the hydrant.

16. All hydrant-lead-valve assemblies shall be blocked against movement with cast in place concrete thrust blocks both behind the hydrant and behind the tee as shown on Figures 2 and 3. Thrust blocks shall bear against undisturbed material.

E. WATERLINE BLOWOFFS

1. All waterline blowoffs shall consist of a mechanical joint anchoring tee, a gate valve with box, corporation stop, 3/4" curb stop with box miscellaneous fittings and piping. The concrete thrust block shall be placed between the undisturbed trench wall and trench bottom and the waterline as shown on the detail. A 2'x 2'x 2' volume of crushed stone shall be placed under the curb stop. A 4'x 4'x 1' volume of crushed stone shall be center under the outlet of the blowoff at ground level. All other items for the waterline blowoff are to be as specified in other sections of this document.

F. WATER SERVICES

1. Refer to Figure 4 of the Standard Detail Sheets for installation details. Tapping into water mains when the air temperature is below 32° F will generally not be allowed. The Owner must be granted special permission to tap water mains when the air temperature is below 32° F by the Town of Halfmoon Water Department. All service connections shall be pressure tested by the Contractor.

2. The complete 1-inch through 2-inch water service shall consist of the tap, corporation stop, branch connection with extra taps and corporation stops if required, copper service pipe and fittings, and curb stop and box. Taps will generally be made by the Owner or their Contractor after the main has been tested, accepted and placed in service. Copper service pipe shall be run in trenches 5 feet depth minimum as measured from finished grade. The curb stop and box shall generally be located on the property or right-of-way line with the top of the curb box set 1 inch above grade in grassed areas and set flush with grade in paved areas.

3. The Contractor shall provide insurance to the Town of Halfmoon, in an amount specified by the Town, prior to tapping an existing waterline. The Town shall be listed as an additional insured on the insurance policy.

4. A complete service for services larger than 2 inches shall generally consist of a main line tee or tapping sleeve and valve, ductile iron service pipe and fittings, and standard gate valve and valve box. Such ductile iron service pipe and fittings shall meet the same specifications that was given previously for the main line pipe and fittings, and shall be installed in a trench to provide at least 5 feet of cover over the barrel of the pipe, all as measured from finished grade.

5. The standard gate valve and valve box shall generally be located on the property or right-of-way line or where required by the Town of Halfmoon Water Department. The gate valve and valve box shall meet the same specifications as outlined in Section V.D for main line valves and valve boxes.

6. Drawings showing the exact configuration of water services larger than 2 inches in diameter shall be reviewed and approved by the Director of Water prior to their construction as outlined in Section II of this document.

7. HDPE or PVC water services are allowed after master meter pits in areas that the Town of Halfmoon will not own or maintain.

G. COPPER WATER SERVICE PIPE & FITTINGS

1. All water services 1-inch through 2-inch in diameter shall be made with copper service pipe. All copper service pipe shall be softer temper Type K seamless copper tubing conforming to ASTM Specification B88 for underground service. Copper service pipe shall have the following dimensions and weights:

Nominal pipe size (inches)	Outside diameter (inches)	Weight per foot (pounds)
1"	1.125"	0.839
1 1/2"	1.625"	1.360
2"	2.125"	2.060

H. CORPORATION STOP AND VALVE

1. 1-inch through 2-inch corporation stops shall have compression connections, and shall be Mueller H-15008 with AWWA (Mueller) inlet threads. Corporation valve shall be of ASTM B62 Brass. Corporation valves shall be ground key design in accordance with AWWA C800

2. Corporation valves shall have a working pressure of 100 psi. A higher pressure rated corporation valve may be required by the Town Water Department based on anticipated pressure in the water system in the area of the connection.

3. Corporation stops shall be installed tilted up at about 15 degrees from horizontal so that a partial loop can be formed in the copper service pipe to allow for possible differential movement of the service pipe and main. A minimum of 5 feet of cover below finished grade shall be maintained over the top of the partial loop in the copper service pipe.

4. Multiple corporation stops for use with branch connections shall be installed 18 inches on center measured along the main and shall be staggered off-line around the circumference of the main.

5. Corporation stop taps larger than the maximum tap size allowable in the main shall not be made. AWWA and DIPRA (Ductile Iron Pipe Research Association) recommendations shall be followed. Consideration shall be given to minimum pipe wall thickness required for each tap size to insure a serviceable threaded connection. Service conditions should indicate the extent of full-threaded engagement necessary. As a guide, tap size should be limited so that at least 3 full threads of the corporation stop are engaged in the pipe wall for ductile iron pipe.

I. BRANCH CONNECTIONS

1. Branch connections shall be 'Y' Type, minimum two branch for 1-inch inlet and 2-inch outlet. Branch connections shall be two branch Mueller H-15343, three branch Mueller H-15071 110 Compression straight couplings shall be used on the outlet end of the branch connections to provide the required compression connection to the 1 1/2" and 2" copper service pipe.

J. CURB STOPS AND BOXES

1. Curb stops for 1-inch through 2-inch copper service pipe shall be non-draining Mueller H-15209. The curb stops shall be set on a solid concrete block. Curb boxes for these curb stops shall be two (2) piece sliding extension type with a stationary rod and arch pattern base suitable for a 5.5 foot deep trench and having a 1-inch inside diameter upper section. Stainless steel rods shall be provided. Curb boxes shall be Mueller H-10314. Lid of curb box shall be one piece with tow holes to fit curb box key.

2. Curb stops shall have a working pressure of 150 psi. A higher pressure rated curb stop may be required by the Town Water Department based on anticipated pressure in the water system in the area of the connection.

3. When curb boxes for 1-inch through 2-inch services are installed in concrete or paved services, cast iron curb box sleeves shall be installed to allow freedom of movement of the ground key lid. Curb box sleeves shall be Mueller H-10342.

K. WATER METERS

1. Water meters for all water services must be obtained from and installed by the Town of Halfmoon Water Department. All water services must be metered. It shall be a misdemeanor offense for which a term of imprisonment exceeding fifteen (15) days but no more than one (1) year may be imposed and or a fine not to exceed one thousand dollars (\$1,000) for individuals or entities to utilize unmetered water.

2. All water meters must be approved by the Director of Water for the Town.

L. INSTALLATION OF WATER SYSTEM

1. In addition to the various miscellaneous installation requirements given in preceding sections of the specification, all water distribution system installation shall be done in accordance with the latest revisions of ANSI/AWWA C600. Also all work shall be done in accordance with the requirements of the Town of Halfmoon Water Department representatives and must be inspected and approved in writing by the Director of Water and/or Town Engineers.

2. Trenches shall be open cut from the surface deep enough to provide a minimum of five feet (5') of cover over the barrel of the pipe from finished grade. Trenches should be wide enough to provide at least six inches (6") of clearance on each side of the bell of the pipe. Refer to Figure 5 of the Standard Detail Sheets for standard trench details.

3. All pipe and fittings shall be laid on good foundations trimmed to shape, and where required, secured against settlement, all in a manner to provide full support for the entire length of pipe. At the joints enough width and depth, including bell holes, shall be made to permit proper jointing. Blocking support of pipe shall not be permitted unless the pipe is to be laid with a concrete cradle or encasement or inside a tunnel or casting pipe. When pipe is laid in tunnels or casings, the pipe shall be blocked in such a manner so as to take the weight off the

bells. Sufficient selected bedding and backfill shall be placed or other precautions taken to prevent flotation, movement, or damage to the pipe, fittings and coatings.

4. Excavation to grade and backfilling shall be done in accordance with the latest revision of ANSI/AWWA C600. When backfilling use satisfactory excavated material, or sand, gravel or other special trench backfill as outlined in this section. The backfill shall be brought by hand or approved mechanical means to a depth of 1 foot over the pipe to provide a cushion and prevent movement and damage to the pipe during subsequent backfilling with equipment. Excavation of rock shall be as shown on Figure 6 of the Standard Detail Sheets.

5. All trench required sheeting and shoring shall be done in accordance with the latest revisions of Title 29 Code of Federal Regulations, Part 1926, Safety and Health Regulations for Construction (OSHA).

6. Materials shall conform to the following specifications:

a. Pipe Zone Bedding (Normal Soil Conditions): Sound, durable sand, gravel, stone or blends of these materials, free from organic, frozen or other deleterious materials, conforming to the requirements of NYSDOT Section 304 and meeting the gradation requirements of NYSDOT Subbase Type 4.

b. Pipe Zone Bedding (Saturated Soil Conditions): Select mixture of graded crushed stone, free from organic, frozen, or other deleterious materials, conforming to the requirements of NYSDOT Section 703-02 and meeting the gradation requirements of NYSDOT Size 2.

c. Pipe Zone Backfill: Sound, durable sand, gravel, stone or blends of these materials, free from organic, frozen or other deleterious materials, conforming to the requirements of NYSDOT Section 304 and meeting the gradation requirements of NYSDOT Subbase Type 4.

d. Suitable Material: Sound, durable sand, gravel, stone or blends of these materials, conforming to the requirements of NYSDOT 203-2.02C and meeting the following gradation requirements:

<u>Sieve</u>	<u>Percent Passing</u>
4"	100
No. 40	0-70
No. 200	0-15

7. Proper and suitable tools and equipment for convenient and proper handling and laying of pipe and fittings shall be used. Care shall be taken to prevent entrance of dirt or foreign matter into the pipe and to prevent damage of pipe lining and coating. Open ends of pipes shall be kept plugged or bullheaded during construction.

8. All material shall be carefully examined for defect and no piece shall be laid which is known to be defective. If any piece is found to be defective, it shall be removed and replaced with a sound piece in a satisfactory manner.

9. Whenever pipes require cutting to fit into other lines, the work shall be done with approved cutting tools specifically designed to cut pipe, so as to leave a smooth end at right angles to the axis of the pipe. The cut end shall be ground or filed to a slight taper so as not to damage rubber gaskets. The spigot ends of pipe shall be installed at the correct depth in the bells with a rubber gasket and two (2) Silicon Bronze Wedges per joint. Plain rubber gaskets shall be used on all mechanical joints. When making plain end connections with a sleeve, ends shall butt together or a filler piece or pipe stop be installed between the ends.

10. In order to be accepted by the Town of Halfmoon Water Department, all valve boxes and curb boxes shall be clean, shall be set squarely down on the valve or curb stop, shall be centered and plumb over the wrench nut of the valve or operating rod of the curb stop, and shall not be over extended. All valves and curb stops shall be suitable marked and adequately protected during construction.

11. Water mains shall be installed at least 10 feet horizontally from any existing or proposed sanitary sewer. The distance shall be measured from edge to edge. In cases where it is not practical to maintain a 10-foot separation, the water main may be installed closer to the sanitary sewer provided that the water main is laid in a separate trench and on an undisturbed earth shelf located on one side of the sanitary sewer at such an elevation the bottom of the water main is at least 18 inches above the top of the sanitary sewer. Water mains crossing sanitary sewers shall be installed to provide a minimum vertical distance of 18 inches between the outside of the water main and the outside of the sanitary sewer. This shall apply whether the water main crosses above or below the sanitary sewer. For all crossings, one full length of water main pipe shall be located so that each joint shall be as far away as possible from the sanitary sewer. Special structural support of the water main and sanitary sewer may be required.

12. In order to control dust conditions during the water main construction, the Contractor shall furnish and apply water only. The use of calcium chloride for dust control shall not be permitted. When water is used on streets or roads, it shall be applied uniformly with a pressure distributor spray bar or by other Town approved equipment. When water is used on areas that shall be sodded or seeded later, it shall be free from acids, oils, salts, or any other substances injurious to plant growth.

M. THRUST BLOCKING AND RESTRAINT

1. All plugs, caps, tees, bends and other fittings shall be provide with concrete thrust blocking to resist test pressures or shall be prevented from moving by using suitable metal rods or clamps. Refer to Figure 3 of the Standard Detail Sheets for typical concrete thrust block details. All concrete to be 3,000 psi and shall be placed around the fittings to completely fill the space between the fittings and the undisturbed walls of the trench. Concrete shall not overlap any joint and shall be placed so as not to interfere with removing or installing any of the jointing hardware.

2. Other means of thrust restraint utilizing anchoring fittings and retainer glands may be used where appropriate.

N. CONNECTION TO EXISTING SYSTEMS

1. Connections to existing systems shall be reviewed and considered on an individual basis by the Director of Water. In general, connections shall be made with minimal or no disruption to the water service in the existing system.

O. TEMPORARY PLUGGING

1. At times when pipe laying is not actually in progress, the open ends of the pipes shall be closed temporarily with pipe plugs or by other means. This shall occur at a minimum of the end of each work day. If water is in the trench when work is resumed, the trench shall be dewatered and the plugs shall not be removed until all danger of water entering the pipe is past.

P. CLEANING LINES

1. At the conclusions of the work, the Contractor shall thoroughly clean all new pipes by flushing with water or other means to remove all dirt, stones, pieces of wood, etc. which may have entered during the construction period. If, after this cleaning, any obstructions remain, they shall be removed to the satisfaction of the Town Engineer and the Town of Halfmoon Water Department. Pipes shall be flushed at a rate of 2.5 feet per second for a duration suitable to the Engineer and the Town of Halfmoon Water Department. The rates of flow required to produce 2.5 feet per second flushing velocity in different sizes of pipe are as shown in the following table:

<u>PIPE SIZE (INCHES)</u>	<u>FLOW REQUIRED TO PRODUCE 2.5 FPS VELOCITY (GALLONS PER MINUTE)</u>
4	100
6	220
8	390
10	615
12	880
16	1,575

Q. HYDROSTATIC TESTING

1. Hydrostatic acceptance tests, consisting of a pressure test and a leakage test, shall be performed on all sections of all water systems installed after the trench has been backfilled. Hydrostatic presumptive tests may be performed when the system is partially complete.

R. DISINFECTION

1. All pipes and fittings connected to and forming a portion of a potable water supply shall be disinfected and flushed in a manner acceptable to the Town Engineer and the Town of Halfmoon Water Department. Disinfection shall be accomplished after the pipe has passed the pressure and leakage tests.

2. Disinfection shall be performed in accordance with the latest version of AWWA C651. Disinfection shall be accomplished by applying a chlorine solution that will give a 50 ppm chlorine residual throughout the main being disinfected. The chlorine solution shall remain in the water mains for a minimum period of twenty-four (24) hours. At the termination of this period, the chlorine residual shall be a minimum of 25 ppm. If the residual is less than 25 ppm, the entire procedure shall be repeated. The chlorine solution shall be thoroughly flushed out prior to placing the new section of the main service. The chlorine solution shall be disposed of in a manner that will in no detrimental way affect fish, plant, or animal life.

3. After the water mains have been flushed with potable water to the satisfaction of the Engineer and the Town of Halfmoon Water Department, samples of water from the mains shall be taken by the Contractor for bacteriological analysis (both coliform and heterotrophic plate count). Two consecutive sets of samples shall be taken 24 hours apart in accordance with AWWA C651.

4. The number of samples and their collection points shall be reviewed with and be acceptable to the Director of Water. The testing laboratory that will do the bacteriological analysis shall be the responsibility of the Owner. The water samples shall test bacteriologically safe before the water mains are placed in service.

S. TIME OF CONSTRUCTION

1. Unless specifically approved by the Director of Water, no water distribution system installation and construction shall take place when the air temperature is below 32° F. The Owner must be granted special permission in writing when the air temperature is below 32° F by the Town of Halfmoon Water Department.

T. RECORD MAPS AND CERTIFICATION

1. At the conclusions of the water system installation, the Contractor shall prepare detailed record maps of the completed water distribution system. These record maps shall be in electronic format and be acceptable to the Director of Water. The Contractor shall also furnish three (3) complete sheets of 22" x 34" prints of these record drawings to the Town of Halfmoon Water Department.

2. Also at the conclusion of the water system installation, the Contractor is required to furnish to the Director of Water, an Engineer's Certification (completed by a New York State Licensed Engineer) stating that the water system is complete and was installed in accordance with the previously submitted and approved plans and specifications. The Director

of Water will submit a copy of the Engineer's Certification to the New York State Public Service Commission.

U. WATER DISTRICT CONTROL

1. All installation and construction of all water mains and services installed in public or private property that are connected directly or indirectly to the Town of Halfmoon Consolidated Water District system shall be subject to the control of the Town of Halfmoon Water Department.

2. Operation of all valves and hydrants under pressure shall be done only by representatives of the Town of Halfmoon Water Department or by such responsible person approved in writing by the Town of Halfmoon Water Department.

3. The Town of Halfmoon Water Department shall be notified in writing at least 24 hours prior to the start of making connections to the existing systems. Also, the Town of Halfmoon Water Department shall be notified in writing at least 24 hours prior to the start of pressure testing, leakage testing and disinfection.

4. The Town of Halfmoon Water Department will not authorize any meter installations, in any subdivision, prior to receiving complete record drawings and New York State Licensed Engineer's certifications and having reviewed and approved the same.

VI. ADMINISTRATION

A. GENERAL

In the event payment is not made as required for usage of water and/or tap fees, that payment shall be added to the tax rolls provided for the next succeeding tax bill. In addition, interest on the unpaid balance shall accrue at the highest legal rate permitted by law for such obligations and the party incurring such expense shall be responsible for all costs of collection, reasonable attorney's fees, disbursements, and expenses incurred in connection with any collection thereafter.

B. ENFORCEMENT OFFICER

The provisions hereof shall be administered and enforced by a person appointed by the Town Board as the "Enforcement Officer". The Enforcement Officer shall be the Director of Water as of the date of this rule and regulation or his designated representative until otherwise determined by the Town Board. No permit or authority required hereunder shall be issued, except in compliance with the provisions of this rule and regulation, or as directed by the Town Board of the Town of Halfmoon. The Enforcement Officer or a Town Board designated representative shall have the power and authority to make such inspections of buildings or premises necessary to carry out his duties in the enforcement of this rule and regulation.

C. ENFORCEMENT

1. Stop Work Orders

Whenever the Enforcement Officer, Director of Water, or designated representative has reasonable grounds to believe that the work on any tap, lateral, or appurtenance is proceeding without permit or is otherwise in violation of the provisions of any applicable law, code, ordinance, rule, or regulation or is not in conformity with any of the provisions of these rules and regulations, or is being performed in an unsafe or dangerous manner, notification will be made to either the Owner of the property or the Owner's agent or the person, firm, or corporation performing the work, to immediately suspend all work. In such instance, any and all persons shall immediately suspend all related activities until the stop work order has been duly rescinded. In the event that the property owner or representative is unavailable, the Code Enforcement Officer should post conspicuously upon the property a stop work order and mail a copy of the same by certified mail or send a facsimile thereof to the Owner, the Owner's agent, or the person performing the work at the last known address on record with the Town of Halfmoon for said entity. If the work has already been completed, the Town has the right to terminate the supply of water to said property.

2. Penalties for Offenses

a. It shall be an "A" misdemeanor for any person, firm or corporation to construct, alter, repair, remove, move, demolish, equip, use, occupy or maintain any lateral, tap or line or portion thereof in violation of any of the provisions of these rules and

regulations or fail in any manner to comply with any notice, directive or order of the Enforcement Officer or designated representative or to conduct, alter or use any pipe, line, hydrant, appurtenances, or part thereof in a manner not permitted by an approved permit issued in accordance with these Rules and Regulations and with the order of the Director of Water. Punishable by a term of imprisonment exceeding fifteen (15) days but no more than one (1) year may be imposed and or a fine not to exceed one thousand dollars (\$1,000) may be imposed.

b. Any individual, partnership, corporation or other firm owning, operating, occupying or maintaining property or premises within the Consolidated Water District or Water District No. 1 must comply with all the provisions of the Town's rules and regulations, the subdivision ordinance, zoning ordinance, and all orders, notices, rules, regulations or determinations issued in connection therewith.

c. Whenever it is found that there has been a violation hereof or of any rule or regulation adopted pursuant to the Town's rules and regulations, an appearance ticket may be issued to the person, individual, partnership or corporation owning, operating or maintaining the premises in which such violation has been noted and or the person, entity, etc. performing the work. If a person served with an appearance ticket fails to appear as directed, a summons or warrant of arrest may be issued by the court on the basis of the accusatory instrument. An Accusatory instrument shall be filed with the Town Court prior to the commencement of the criminal action.

e. An appearance ticket or other orders or notices referred to in these rules and regulations or in any other Town ordinances shall be served on the Owner or one (1) of the owner's executors, legal representatives, agents, lessees, (2) any tenant or other person occupying the premises or other person having a vested or contingent interest in the premises, either personally or by certified mail, addressed to the last known address, can be served by facsimile, if any, of the owner or one (1) of: the owner's executors, legal representatives, agents, lessees or other person having a vested or contingent interest in name, as shown by the last preceding completed record of the Receiver of Taxes or in the Office of the County Clerk.

f. The Code Enforcement Officer shall have the authority, pursuant to the Criminal Procedure Law, to issue an appearance ticket subscribed by him, directing a designated person to appear in court at a designated time in connection with the commission of a violation of hereof or any order made thereunder.

g. Any person who shall fail to comply with a written order of the Code Enforcement Officer his designated representative within the time fixed for compliance therewith and any owner, builder, architect, tenant, contractor, subcontractor, plumber, construction superintendent, or their agent's or any other person taking part of assisting in the construction or use of any building who shall violate any of the applicable provisions herewith the Town's rules and regulations or any lawful order, notice directive, permit or certificate of the Code Enforcement Officer of in addition to any other provision of the Town's rules and regulations or any rules or regulations adopted pursuant to this regulation or who shall violate or fail to comply with any order made thereunder shall be guilty of an "A" misdemeanor punishable by a term of imprisonment exceeding fifteen (15) days but no more than one (1) year may and/ or

a fine not to exceed one thousand dollars (\$1,000). Each Day that such violation shall continue shall be a separate violation and is subject to a separate fine, imprisonment or combination thereof.

h. Notwithstanding a conviction for an offense against any provisions or sections, an association or corporation convicted of a violation herewith shall be subject to revocation of any permit therein granted without reimbursement of fees paid thereof.

i. In lieu of, or in addition to, any fine or imprisonment, or both, imposed for a conviction of any offense herewith, each such offense may be subject to a civil penalty not to exceed two hundreds (\$250.00) dollars to be recovered in an action or processing in a court of competent jurisdiction. Each day an offense continues shall be subject to a separate civil penalty.

j. The Town Attorney may maintain an action or proceeding in a court of competent jurisdiction to compel compliance with this Article, notwithstanding the previous provisions of this subsection, for a penalty or other punishment.

3. Liability of Town and Employees For Damages

The Town's rules and regulations shall not be construed to hold any code enforcement officer of the Town of Halfmoon or the Town of Halfmoon responsible for any damages to persons or property by reason of the inspection or re-inspection authorized herein or failure to inspect or reinspect as required by the permits under the Town's rules and regulations nor shall it be liable for any damage to persons or property by reason of the Code Enforcement Officer exercising their discretion as provided in the Town's rules and regulations.

a. Notification of Violations. Written notice of violation signed by the Code Enforcement Officer shall be served upon the person or persons committing such violation either personally or by mail addressed to such person or persons at his or her last known address. Each week's continued violation shall constitute a separate additional violation.

b. Complaints. Whenever an alleged violation of the Town's rules and regulations occurs, any person may file a complaint in regard thereto. All such complaints must be in writing and shall be filed with the Code Enforcement Officer who shall properly record such Complaint and immediately investigate and report thereon. All such complaints shall be signed by and bear the address of the complainant.

VII. FEES & SCHEDULE

A. WATER METER AND INSTALLATION FEE

5/8" X 3/4" WITH ACCESS.....	\$350.00
3/4" WITH ACCESS.....	\$380.00
1" WITH ACCESS.....	\$440.00
1 1/2" WITH ACCESS.....	\$680.00
2" WITH ACCESS.....	\$810.00
4" WITH STRAINER.....	\$2,360.00
6" WITH STRAINER.....	\$4,230.00
8" WITH STRAINER.....	\$6,585.00

COMPOUND METERS

3" WITH STRAINER.....	\$3,780.00
4" WITH STRAINER.....	\$4,550.00
6" WITH STRAINER.....	\$6,650.00
8" WITH STRAINER.....	\$7,250.00

B. SERVICE WORK

FEE FOR TESTING METER.....	\$50.00
LABOR.....	\$30.00 PER HOUR
BACKHOE/OPERATOR.....	\$95.00 PER HOUR
DUMP TRUCK.....	\$75.00 PER HOUR
PARTS.....	AS PER CURRENT COSTS

**PRICES SUBJECT TO CHANGE YEARLY.*

C. WATER SYSTEM ASSESSMENT SCHEDULE

The following schedule defines the assessment for all properties within the Town of Halfmoon. Units shall be assessed by the Town on the basis of the below assessments or based on computed usage by the Town, whichever is greater.

WATER SYSTEM ASSESSMENT SCHEDULE

The Town Board reserves the right to reassess any parcel which, in its belief, is not assessed in accordance with the actual benefit received by that parcel (may be calculated based on actual water usage).

The Town Board also reserves the right to assess any parcel that contains multiple uses in accordance with the actual water used by each business or in its' discretion based upon the actual uses contained therein (ex. a commercial building with a restaurant and retail will have uses calculated separately to arrive at total).

Definitions:

Unit = equivalent domestic unit (EDU).

SF = square feet.

Unit Calculation Notes:

1. Parcels of land greater than 1 acre will be rounded to the nearest whole acre. For example, 1.49 acres is rounded to 1 acre and 1.50 acres is rounded to 2 acres.
2. The building area square footage will be rounded to the nearest 1,000 SF. For example, 499 SF is rounded to 0 SF and 500 SF is rounded to 1,000 SF.

I. RESIDENTIAL

A. One Family, Two Family, Three Family Residences

1.0 Unit per Dwelling (ex. one family – one unit, two family – two units, three family – three units). If greater than 1 acre, add 0.01 Unit for each additional 1 acres or fraction thereof.

B. Mobile Home Parks/Mobile Homes

1.0 Unit per Mobile Home Unit. If greater than 1 acre, add 0.01 Unit for each additional 1 acres or fraction thereof.

C. Apartments

1.0 Unit per Apartment Unit

D. Camps/Cottages

0.5 Unit per camp (non-winterized and less than 750 SF). If winterized or greater than 750 SF, assess as residential.

E. Vacant Land

0.1 Unit for first acre. Add 0.01 Unit for each additional acre.

II. COMMERCIAL

A. Auto Dealers – Sales and Service

1.0 Unit, plus 1.0 Unit per 1,000 SF of building area

B. Banks

1.0 Unit, plus 1.0 Unit per 2,000 SF of building area

C. Business – Professional Office

1.0 Unit per individual business, plus 1.0 Unit for each 2,000 SF of building area in excess of 2,000 SF.

D. Business – Office Complexes

1.0 Unit, plus 1.0 Unit for each 3,000 SF of building area in excess of 3,000 SF.

E. Business – Retail Sales

1.0 Unit, plus 1.0 Unit per 3,000 SF of building and business area.

F. Car Wash

1.0 Unit, plus 1.0 Unit per stall or fraction thereof (may be adjusted based on actual water use).

G. Manufacturing

1.0 Unit, plus 1.0 Unit per 10,000 SF building area

H. Restaurant – Traditional

1.0 Unit, plus 1.0 Unit per 1,000 SF of building and business area

I. Restaurant – Banquet Hall

1.0 Unit, plus 1.0 Unit per 1,000 SF of building area

J. Utility

1.0 Unit, plus 1.0 Unit per 1,000 SF of building area

K. Warehouse (Storage and Distribution Centers)

1.0 Unit, plus 1.0 Unit per each 10,000 SF of building area in excess of 10,000 SF

D. DISTRICT EXTENSION FEE

1. Each unit will be subject to a minimum of \$1,500 per unit fee (subject to change per Board resolution), which is to be paid in full for all EDU's prior to final stamping of plans (see Section VII.C for water system assessment schedule). The Director of Water shall have the authority to exempt any unit from the \$1,500 per unit fee so long as the application involves four (4) or less EDU's within a two (2) year period.

2. Additional charges or donations may be collected as deemed in the best interest of the Town based on determination of the Town Board.

E. APPLICATION REVIEW

1. Make application with Water Department, including map and narrative.

VIII. DOMESTIC WATER RATE SCHEDULE

Town of Halfmoon Consolidated Water District	
Quarterly Water Usage Per Meter	Water Rate per 1,000 gallons
4,000 to 30,000 gallons per quarter	Base Rate
30,001 to 50,000 gallons per quarter	Base Rate x 1.5
Greater than 50,000 gallons per quarter	Base Rate x 2.0

Notes:

- 1. Base Rate is currently \$3.35.*
- 2. Base rate is established in annual budget and may be modified at any time subject to the discretion of the Town Board.*

IX. MANUFACTURING WATER RATE SCHEDULE

The manufacturing water usage rate shall be the same as the domestic water base rate for the first 9,000,000 gallons used in any billing quarter and that any metered water utilized after 9,000,000 gallons shall be billed at seventy-two percent (72%) of the domestic water base rate.

APPENDIX A

STANDARD DETAIL SHEETS

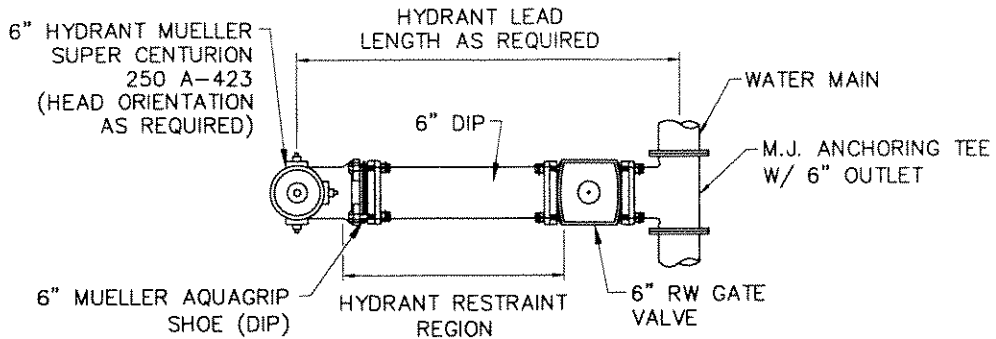

PLAN

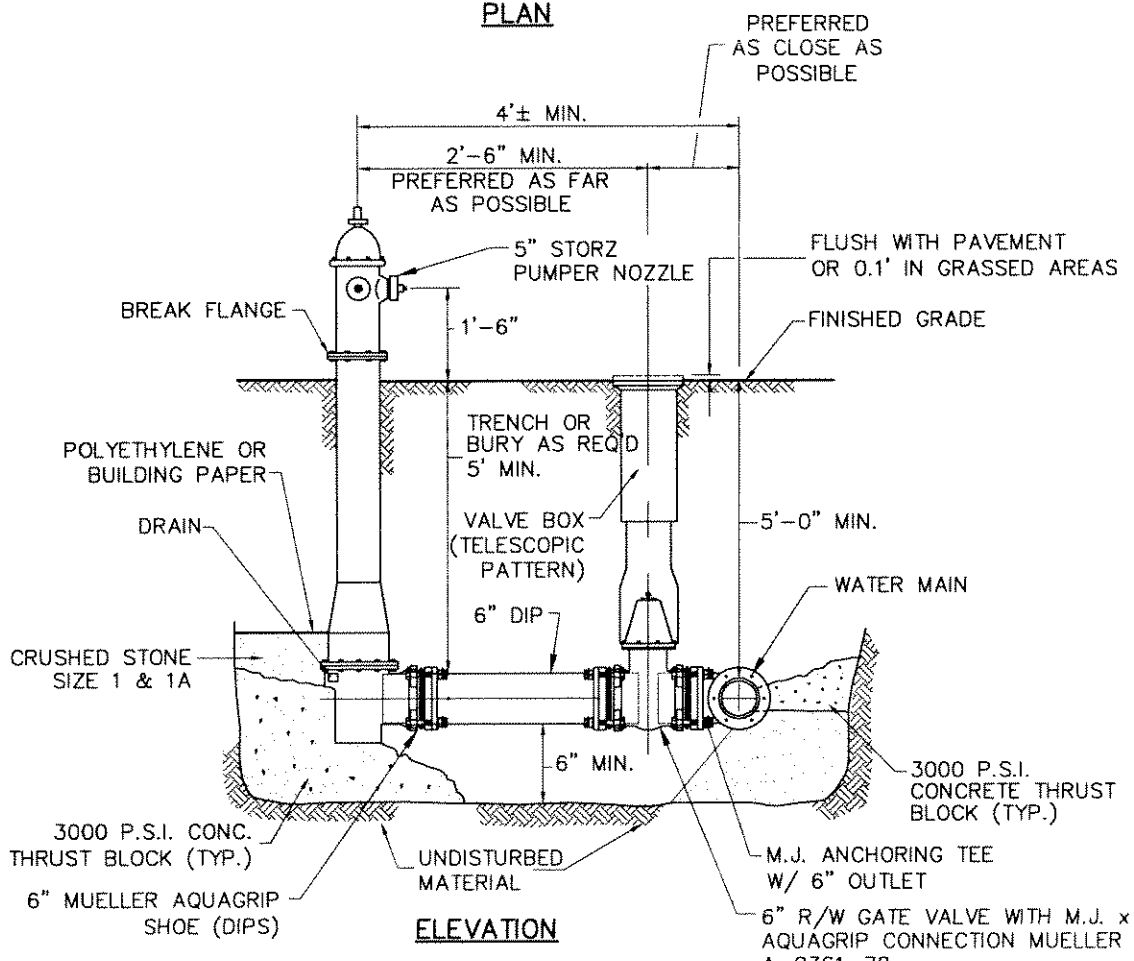

ELEVATION

NOTES:

1. HYDRANT TO BE INSTALLED WITHIN RIGHT-OF-WAY (R.O.W.).
2. PROPOSED LOCATION OF HYDRANT TO BE FIELD LOCATED (PAINTED) AND APPROVED BY TOWN AND TOWN ENGINEER PRIOR TO INSTALLATION.

TYPICAL HYDRANT INSTALLATION DETAIL
NOT TO SCALE

File: W:\0303\303\WATER REG. LAYOUTS\CHAS\0303\0303.dwg Date: 4/12/2006 1:13:31 PM Plotted: 4/12/2006 1:09:26 PM Plotter: 4/12/2006 1:13:31 PM User: lammerick, User: j

Drawing Copyright © 2006 Clough, Harbour & Associates LLP



CLOUGH HARBOUR & ASSOCIATES LLP
111 Winners Circle, PO Box 5269 - Albany, NY 12205-0269
Main: (518) 453-4500 • www.cloughharbour.com

TOWN OF HALFMOON
SARATOGA COUNTY, NEW YORK

PROJECT NO.
9003

DATE: APRIL 2006

FIGURE 2

**REQUIRED BEARING AREAS & DIMENSIONS
FOR CONCRETE THRUST BLOCKS**

PIPE SIZE (IN.)	TEE(See Note 5)		90°(1/4)BEND		45°(1/8)BEND		22-1/2°(1/16)BEND		11-1/4°(1/32)BEND	
	AREA Sq.Ft.	Dimen. D x L	AREA Sq.Ft.	Dimen. D x L	AREA Sq.Ft.	Dimen. D x L	AREA Sq.Ft.	Dimen. D x L	AREA Sq.Ft.	Dimen. D x L
6	3.2	1.5 x 2.5	4.5	2.0 x 2.5	2.4	1.5 x 2.0	1.2	1.0 x 1.5	0.6	1.5 x 1.5
8	5.7	2.0 x 3.0	8.0	2.0 x 4.0	4.3	2.0 x 2.5	2.2	1.5 x 1.5	1.1	1.0 x 1.5
10&12	12.7	3.5 x 3.5	18.0	4.0 x 4.5	9.7	2.5 x 4.0	5.0	2.0 x 2.5	2.5	1.5 x 2.0
16	50.0	6.0 x 8.5	50.0	6.0 x 8.5	27.0	5.0 x 5.5	13.8	3.5 x 4.0	6.9	2.5 x 3.0
24	72.0	8.0 x 9.0	72.0	8.0 x 9.0	39.0	5.0 x 8.0	20.0	4.0 x 5.0	10.0	3.0 x 3.5

TYPE A BLOCKING FOR 11 1/4° & 22 1/2° VERT BENDS					
PIPE SIZE NOM DIA(INCHES)	VERTICAL BEND DEGREES	NO. OF CURT OF CONC BLOCKING	SIDE OF CURB (FEET)	DIA OF SHACKLE RODS(2) (INCHES)	DEPTH OF RODS IN CONC (FEET)
8"	11 1/4°	28	3.0	3/4"	1.6
	22 1/2°	55	3.8		
10"	11 1/4°	42	3.5	3/4"	1.6
	22 1/2°	83	4.4		
12"	11 1/4°	60	3.9	3/4"	1.6
	22 1/2°	118	4.9	7/8"	2.2
16"	11 1/4°	104	4.7	7/8"	2.2
	22 1/2°	205	5.9	1 1/8"	3.7
24"	11 1/4°	229	6.1	1"	2.9
	22 1/2°	450	7.7	3/8"	5.7

TYPE B BLOCKING FOR 45° VERTICAL BENDS				
PIPE SIZE NOM DIA(INCHES)	NO. OF CURT OF CONC BLOCKING	SIDE OF CURB (FEET)	DIA OF SHACKLE RODS(2) (INCHES)	DEPTH OF RODS IN CONC (FEET)
8"	102	4.7		
10"	154	5.4	3/4"	1.6
12"	218	6.0		
16"	378	7.2	1 1/8"	3.7
24"	832	9.4	1 3/8"	5.7

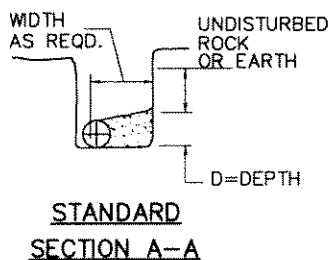
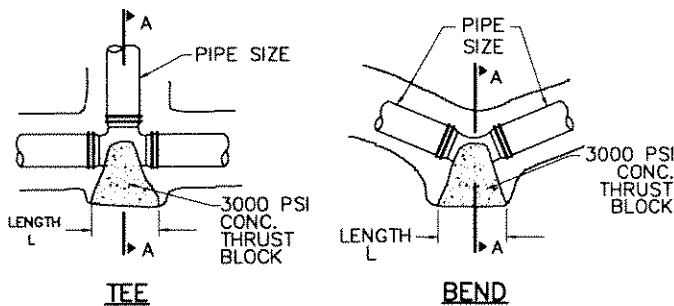
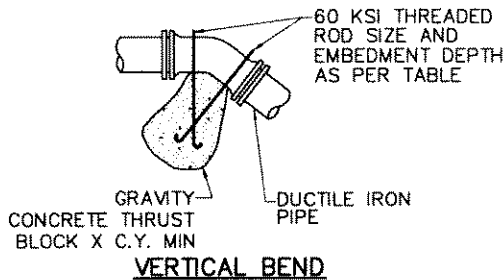

THRUST BLOCK NOTES

- FOR REQUIRED BEARING AREA DIMENSIONS D & L SEE TABLE. DIMENSIONS OF D & L OTHER THAN THOSE SHOWN IN THE TABLE MAY BE USED PROVIDED THEY YIELD A BEARING AREA EQUAL TO OR LARGER THAN THAT REQUIRED.
- CONCRETE NOT TO OVERLAP ANY JOINT.
- CONCRETE TO BE PLACED SO AS NOT TO INTERFERE WITH REMOVING OR INSTALLING ANY OF THE JOINTING HARDWARE.
- APPROXIMATE VOLUME OF CONCRETE THRUST BLOCK:

$$V = \frac{LD(W+ID) - ID^3}{81}$$

WHERE:
 V = VOLUME IN CUBIC YARDS
 L = LENGTH OF BLOCK IN FEET
 D = DEPTH OF BLOCK IN FEET
 W = WIDTH OF BLOCK IN FEET
 ID = INSIDE DIAMETER OF PIPE IN FEET
- VALUES FOR TEE ALSO APPLY TO END PLUGS, CAPS, AND TAPPING SLEEVES.
- REQUIRED BEARING AREAS ARE DUE TO THRUSTS CAUSED BY 150 PSI WORKING PRESSURE PLUS 50%(75 PSI) SURGE ALLOWANCE RESULTING IN 225 PSI TOTAL INTERNAL PRESSURE. NORMAL PIPE DIAMETER USED.
- REQUIRED BEARING AREAS ARE BASED ON ALLOWABLE SOIL BEARING CAPACITY OF 2000 LBS. PER SQUARE FOOT FOR SAND. DUE TO OTHER SOIL CONDITIONS ENCOUNTERED, BEARING AREAS MAY BE MODIFIED BY THE ENGINEER.
- IN MUCK, PEAT, OR RECENTLY PLACED FILL ALL THRUST SHALL BE RESISTED BY PILES OR TIE RODS TO SOLID FOUNDATIONS, OR BY REMOVAL OF SUCH UNSTABLE MATERIAL AND REPLACEMENT WITH BALLAST OF SUFFICIENT STABILITY TO RESIST THE THRUSTS, ALL AS REQUIRED BY THE ENGINEER.

TYPICAL THRUST BLOCK DETAIL
NOT TO SCALE

Drawing Copyright © 2006 Clough, Harbour & Associates LLP



CLOUGH HARBOUR & ASSOCIATES LLP
 111 Winners Circle, PO Box 5269 • Albany, NY 12205-0269
 Main: (518) 453-4500 • www.cloughharbour.com

TOWN OF HALFMOON
SARATOGA COUNTY, NEW YORK

PROJECT NO. 9003
DATE: APRIL 2006
FIGURE 3

1/16/2006 1:13:48 PM User: lamont@cha.com Sheet: 4/10/2006 1:13:48 PM Title: 45°(1/8) BEND FOR CONCRETE THRUST BLOCKS

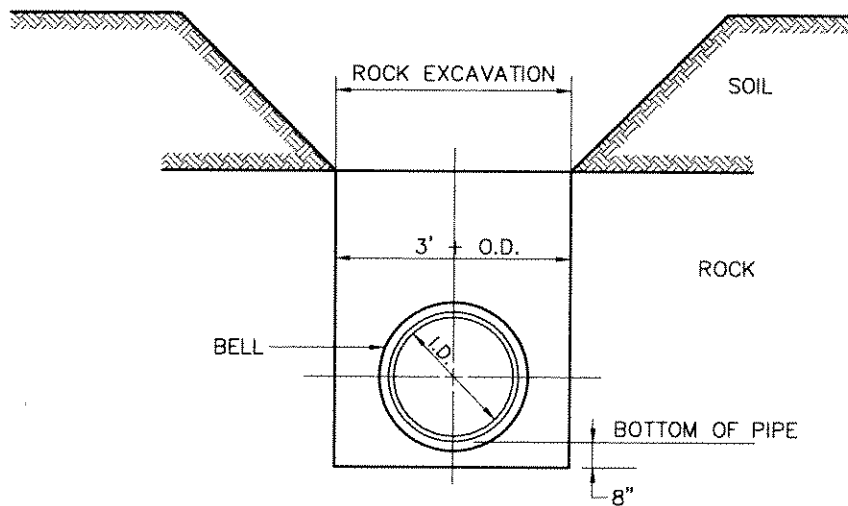

TYPICAL TRENCH WITH ROCK EXCAVATION DETAIL
NOT TO SCALE

P:\MISC\2007\WORK\110-LIPSAN'S\ROCK_EXCAVATION.DWG 7/27/2006 9:20:50 AM Plotted 4/10/2006 1:08:32 PM User: Ljennrich Size: J

Drawing Copyright © 2006 Clough, Harbour & Associates LLP



CLOUGH HARBOUR & ASSOCIATES LLP
 III Winners Circle, PO Box 5269 - Albany, NY 12205-0269
 Main: (518) 453-4500 • www.cloughharbour.com

TOWN OF HALFMOON
 SARATOGA COUNTY, NEW YORK

PROJECT NO.
9003

DATE: APRIL 2006

FIGURE 6